



# ELW ROWPU

Reverse Osmosis  
Water Purification Unit





# ROWPU

HIGH PERFORMANCE REVERSE OSMOSIS WATER PURIFICATION. Highly manoeuvrable, economic and effective, surpassing levels of purity set by the World Health Organization (WHO).



Clean and fresh drinking water is a scarce resource in today's world. The ELW ROWPU is a compact mobile water purification unit that is able to purify potentially hazardous water to potable water in minutes.

ALL TRANSPORT:



ALL WEATHER:



### Trust The Specialists

ELW Global Limited specialises in field support equipment intended for humanitarian, military and emergency relief operations.

Our product range includes:

- Trailer-mounted reverse osmosis water purification units (ROWPUs).
- Portable 'containerised' water purification plants.
- Static long term water purification solutions

All ELW's water treatment solutions can be customised according to clients requirements.



ELW Global Limited  
Email : [info@elwglobal.com](mailto:info@elwglobal.com)  
[www.elwwater.com](http://www.elwwater.com)  
[www.elwglobal.com](http://www.elwglobal.com)

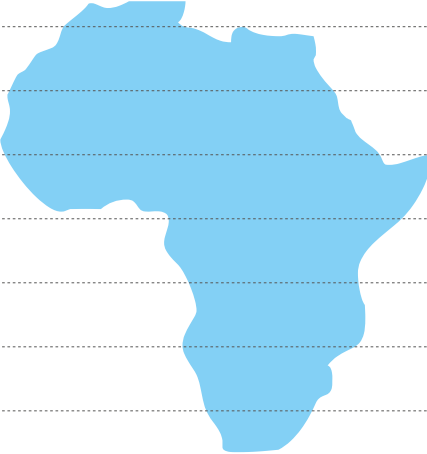

WHERE THERE IS GREATER RISK OF CONTAMINANTS,  
REVERSE OSMOSIS PURIFICATION IS REQUIRED.

- 
- 1 FLOCCULATION
  - 2 CHLORINATION
  - 3 METAL REMOVAL (Madox or Exfetron)
  - 4 COLOUR, TASTE AND ODOUR REMOVAL (Activated Carbon)
  - 5 PARTICAL FILTRATION 10 MICRON
  - 6 REVERSE OSMOSIS
  - 7 ANTI-SCALANT DOSING
  - 8 UV RADIATION (Fitted to storage tank exit for consumer usage)



# The Purification Process

Filtration is the removal of particles from water while purification is the removal of all non-water atom sized components. The purification process used in the ELW ROWPU brings surface waters to World Health Organization (WHO) standards.

**STEP 1** Raw water is pumped into the system and passes the flocculation dosing point. Chemically treated water then runs through the special mixing manifold where flocculation starts taking place.

**STEP 2** Madox/Exfetron exposure is used to remove iron, lead, manganese and other metal particles.

**STEP 3** Sand Filtration removes sediment, small twigs, sand and dust particles down to 10 microns.

**STEP 4** Activated Carbon filter is used to remove any taste, odours and colour from the water.

**STEP 5** Five or Ten Micron Stainless Steel filters are used to remove remaining particles.

**STEP 6** Sterilization by means of Chlorination completes the filtration process.

**The Reverse Osmosis (RO) stage, for heavily contaminated water, now begins. This is recommended in any situation where contaminants cannot be constantly monitored and quality must be ensured.**

**STEP 7** The purpose of the UV light is to kill off any remaining bacteria.







# Features



## Production Capacity

ELW Global produce a variety of ROWPUs and will strive to meet every requirement.

The flagship product is the 2K ROWPU. For highly contaminated water, the output is 2000 litres of Reverse Osmosis Water per hour. For less contaminated water sources, 5000 Litres per hour of filtered water is produced.

**2,000/** litre  
ph  
REVERSE OSMOSIS  
WATER

**5,000/** litre  
ph  
FILTERED WATER



## Increased Lifespan - Reduced Costs

All ELW Water Purification trailers use the highest grade components, cutting down on the maintenance and logistical support costs.

Low grade disposable filters have been replaced with stainless steel washable filters. Chlorine powder is used rather than sodium hypochlorite for further savings on operating costs. All water filtration units are fitted with a Clean In Place (CIP) system that allows for membranes to be cleaned without being removed, saving even more time, energy and money.



## Energy Efficient

ELW's mobile units are equipped with a 5 Kva generator that provides the necessary power to the water purification system. A solar (PV) option can be integrated on request. A solar and generator hybrid unit is currently in development.



## A Short Term Solution That Makes Economic Sense

For projects based in Africa, purchasing is not the only way to benefit from ELW Global products. ELW offer a lease option to those companies, governments and NGO's whose water purification requirement is short term, in which case leasing may prove to be a more economic solution.



## User Friendly & Low Maintenance

All valves, gauges, fittings and filters are clearly labelled for easy identification, access and adjustment.

All units are designed to be weather proof for longevity. Optional storage bladders also can be supplied to increase the capacity of stored water.

# Standard Fitted Operational Equipment

## SUPPLIED AS STANDARD:

- Storage bladders 5000, 10000 or 20000 litres
- Bladder repair kit
- Pick-up hose and foot valve for pumping from river or lake source (5 metre)
- Supply hose (15 metre)
- Water hose (15 metre)
- Waste water hose (15 metre)
- Diesel power generator (19Amp, 5kVa)
- Chlorine tester/pH tester/TDS meter
- CIP (Clean In Place) system for extending life of membranes beyond 4 years





# ROWPU Trailer

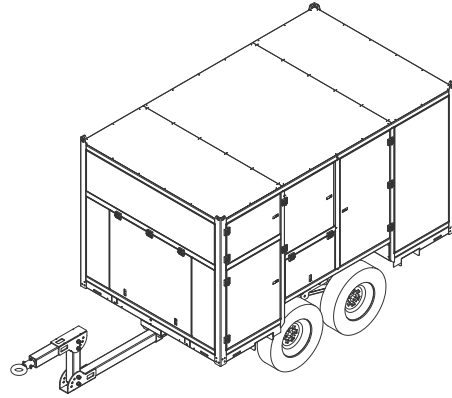

## Trailer

All ELW Global trailers are designed and manufactured to military grade levels of durability and adaptability.

They are designed for off-road use across the toughest terrain. A capability that can prove vital in accessing water sources close to rocky and sandy ground.

## Drawbar

The ROWPU drawbar is adjustable allowing the trailers to be towed by a variety of vehicles and trucks typically found in the field. The drawbar can be removed for transport purposes, providing a cost saving feature.

## Power Generator Specification

The diesel generator output is 19.6 Amp (230V/50Hz), more than enough to supply all the electricity requirements for the ROWPU.

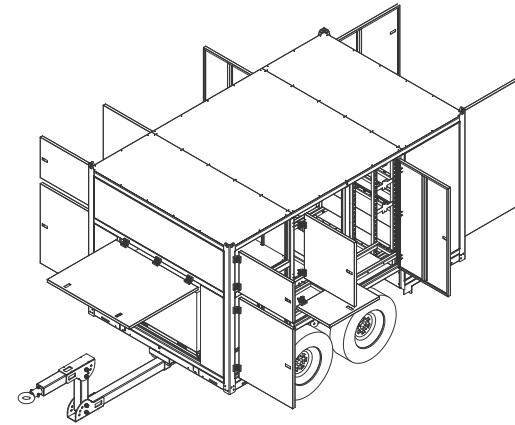

## Chassis

The ROWPU chassis features mounting points, forklift slots, fastening points and lifting points as well as drawbar and suspension mounting points. For rust resilience it is zinc treated and powder coated.

The trailer and chassis are available in a variety of colours.

## Suspension

A suspension built to military grade specification ensures the smoothest of movement over rough terrain. Construction includes double independent coil and shock assembly with a rear facing swing-arm to withstand the assault of the harshest environments.





# Large Scale Solutions



## Permanent Water Systems

ELW Global produce a range of mobile and static purification units. If the water purification requirement is permanent, our technologies can be built into shipping containers, prefabricated or fixed buildings.

When installing components into permanent buildings, the purification capabilities can be increased to cater for requirements exceeding 50,000 litres per hour.

## ROWPU 10K

### From Concept to Product:

In November 2011, ELW Global were commissioned by the Botswana Water Board to design, manufacture and supply two 10,000 litre per hour water purification units to react to the water crisis.

Within 6 weeks ELW Global were able to supply the surrounding villages with clean filtered water. To this day ELW are providing an extra 20,000 litres per hour to the local population.

## Water Storage

ELW is also able to supply and install a broad range of water storage solutions, all built to the highest standards.

Water Storage Products include: Mesh Reservoirs, Panel Reservoirs, S-Tanks (Onion Tanks), Sectional Tanks, and Bladders.

To discuss the options available to suit every requirement and budget, contact [info@elwglobal.com](mailto:info@elwglobal.com).

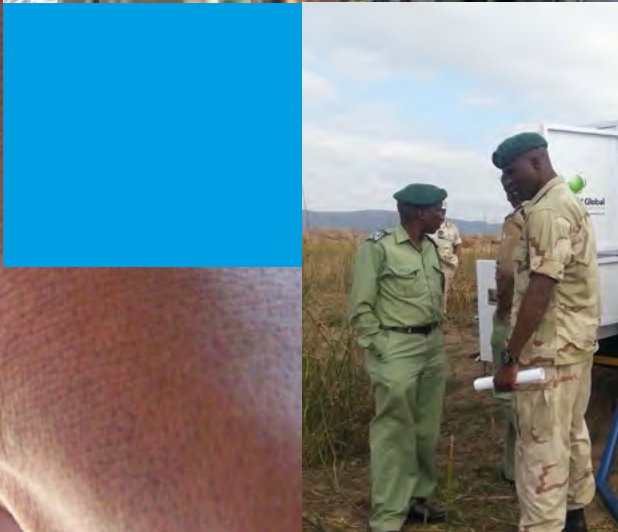



# Global Projects



High quality and efficiency have made ELW Global's water purification solutions and services the 'go to' choice of contributing countries to United Nations programmes.

ELW's presence in key countries has resulted in the operation of training and maintenance programmes in both French and English, in Africa.



ELW Global solutions currently support the following programmes.

- 1 **UNAMID** - Darfur
- 2 **AMISOM** - Somalia
- 3 **Disaster Relief** - Haiti
- 4 **Formed Police Unit (FPU)** - Senegal
- 5 **Formed Police Unit (FPU)** - Rwanda
- 6 **Water Affairs** - Botswana









# Find Us Online

Go to the link below or scan the QR code with your phone to see a video demonstration of the ELW ROWPU 2K installation.

<http://militaryrowpu.com>



GET YOUR QR SCANNER  
<https://scan.me/download>



**ELW Global**  
Limited

ELW Global Limited  
Email : [info@elwglobal.com](mailto:info@elwglobal.com)  
[www.elwwater.com](http://www.elwwater.com)  
[www.elwglobal.com](http://www.elwglobal.com)

