

# DFK

A NEW STANDARD  
IN FIELD CATERING  
SUPPORT.



## Diesel Field Kitchen

The ELW Diesel Field Kitchen is a state of the art catering system, designed and manufactured in South Africa.

The Diesel Field Kitchen uses multi grade diesel as the primary heat source to provide **food for up to 800 people per day**. Setup and positioning of the DFK **takes no more than 6 minutes**, making it one of the most adaptable mobile diesel field kitchens in the world.

ALL TRANSPORT:



ALL WEATHER:



ELW Global Limited, pioneers in Diesel Field Kitchen (DFK) technology, uses patented Clean-burning Diesel Technology (CDT), which brings a greener solution to its range of mobile field kitchens designed for use in remote and inaccessible areas.

The latest CDT innovations are key to the safe and clean use of Diesel in the field. The DFK design incorporates new features improving the speed with which it can be deployed therefore providing faster access to cooked food and hot liquids in military, peacekeeping, disaster and commercial operations in remote areas.

ELW Global continues its innovation in this area and is able to offer custom-built options to suit all its customers' needs.



ELW Global Limited  
12 Quark Crescent, Linbro Business Park  
Sandton, 2090, Johannesburg  
South Africa

Office : + 27 11 608 2515  
Email : info@elwglobal.com

www.elwtactical.com  
www.dieselfieldkitchen.com



# DFK



## Diesel Oven

### The Oven

The diesel powered oven is the heart of the Field Kitchen and has been developed with functionality in mind. Its unique heat management system takes the guesswork out of field catering and makes it easier for chefs to use without specialist training.

The patented Diesel Burner is designed to burn high or low quality diesel fuel without issue. The oven consists of top plates that have the capacity to cook up to 200 litres of food and the oven has a capacity of 175 litres, thus making it one of the largest volume mobile kitchens available. The top plates are designed to make use of various size cooking pots, pressure cookers and fryers. The oven is designed for baking and roasting.

Additional add-on options include a built-in hot water geyser and storage tank to make the DFK even more encompassing to the outdoor catering experience.

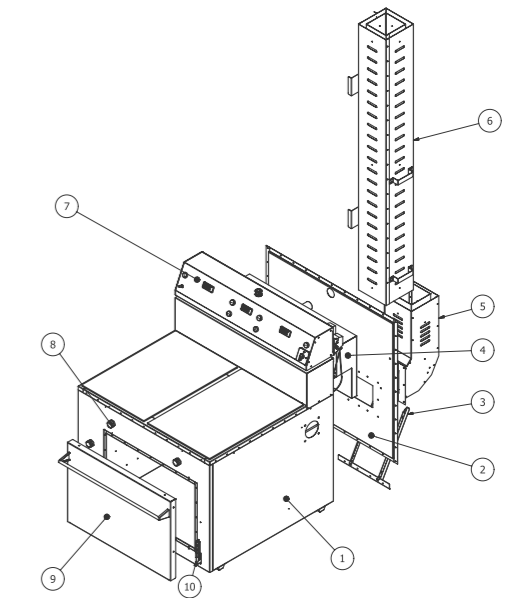

### Temperature control

The digital temperature control system allows full individual heat control of each stove plate and the oven. The chef has full control over the cooking temperatures to achieve the desired result.



### Fuel storage & configuration

The two diesel fuel tanks have level gauges and quick couplers allowing the operator to switch tanks hygienically with ease.

- |                               |                               |
|-------------------------------|-------------------------------|
| 1 ..... OVEN ASSEMBLY         | 6 ..... EXHAUST UPPER SECTION |
| 2 ..... COVER REAR            | 7 ..... ELECTRIC PANEL        |
| 3 ..... EXHAUST BRACE         | 8 ..... KNOB REGULATING       |
| 4 ..... WATER HEATER TANK     | 9 ..... OVEN DOOR             |
| 5 ..... EXHAUST LOWER SECTION | 10 ..... OVEN DOOR HINGE      |



# DFK

ELW GLOBAL'S  
INNOVATIONS ARE  
KEY TO THE SAFE  
AND CLEAN USE OF  
DIESEL IN THE FIELD.



OVEN TOP PLATE ARRANGEMENT OPTIONS

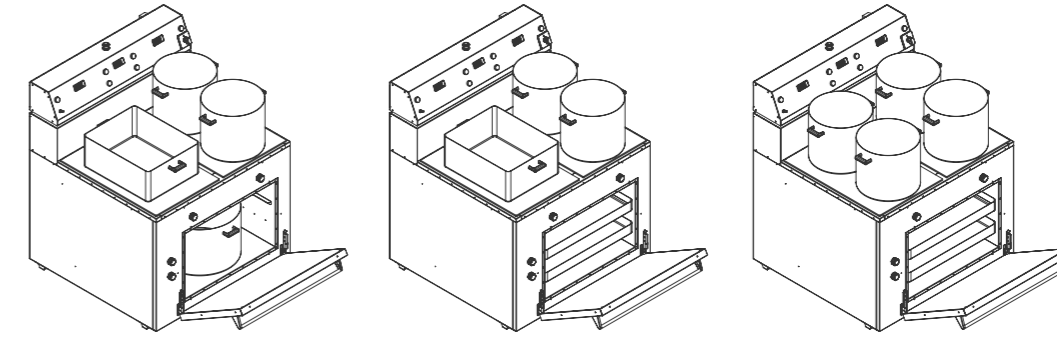

## Catering and Menu

The Diesel Oven design has many commercial components that reduce the requirement for specialised pressure boiling pots and pans. A wide range of meals can be prepared on the diesel oven, just as you would be able to cater for people with a commercial oven.

Boiling Pots, pans, and baking trays, allow the user to cook multiple meals, offering advantages when catering for different cultural diets.





## Training & Support

The DFK runs on the same multi grade fuel powering 90% of other field support vehicles, providing field operations with the best chance of redeploying their catering system at short notice.



### Operator Training

ELW Global has a team of trainers capable of training in French and English on the DFK.

The training programme covers topics from introduction and familiarisation, to setup and operational instructions and maintenance on the DFK. Training methods include practical and theoretical lessons in the field and in the classroom.

Certification is issued upon completion to students that comprehend the DFK.





# Standard Fitted Operational Equipment

All equipment provided as standard is stored for transportation within the cupboard and storage space built in to the unit so no equipment is transported externally.

The following equipment is supplied as standard:

## Cooking Utensils, pots and pans:

- 50 litre pot
- 40 litre fryer
- Grilling pan
- Baking tray
- 40 Litre urn for hot water

## Tools and accessories:

- Speed wrench
- Wheel spanner
- Spanner set
- Screwdriver set
- Triangle
- Fire extinguisher
- Fire blanket
- First aid kit
- Batteries
- Multi voltage management system

## Optional extras available are:

- Water bladders (many sizes available)
- Macerator
- Fat trap
- Solar panels
- Integrated bain-marie
- Any other cooking utensils and equipment
- Built-in hot water geyser with storage tank
- Additional awnings
- Lock down pots and pans

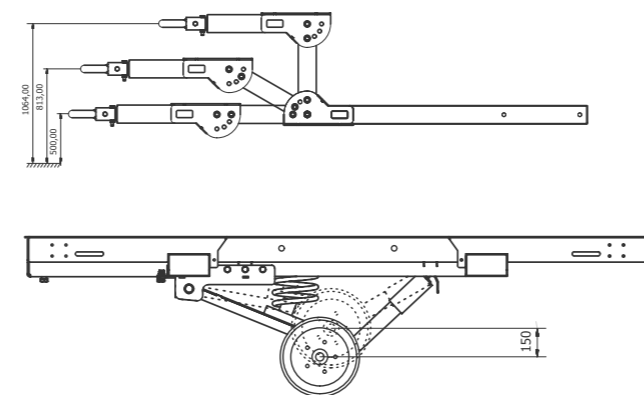

## Drawbar

The DFK drawbar is a single beam drawbar which is rated and tested and allows a wide variety of vehicles and trucks to tow the DFK. The drawbar is adjustable and can be removed to assist transportation.

## Suspension

The suspension consists of independent coil and shock assembly with a rear facing swing-arm, to allow for smooth movement over rough terrain and off road conditions. The suspension allows for movement of 150mm.

## Brakes

A handbrake is fitted to the drawbar. An optional run-in brake or electrical system can be provided if required.

# DFK Components

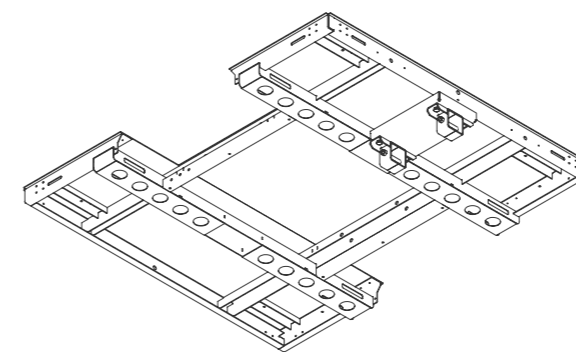

## Chassis

The DFK chassis features pre-cut mounting points, forklift slots, fastening points, fold-down-side mountings, rubber stoppers, landing legs and drawbar suspension. The chassis is zinc treated and powder coated. A variety of colours are available.

## Cupboards

The cupboards are manufactured from mild steel with food grade stainless steel tops. They provide storage space for cooking utensils and equipment and also house the fuel tanks and other operational equipment.

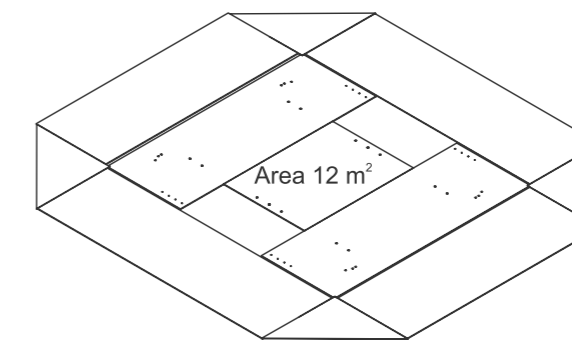

## Floor

The floor of the unit is made from aluminium tread plate. The total area is 12m<sup>2</sup>, which is ample space for up to 4 persons.

## Side Panels

All side panels are designed to fold out and serve as both the platform and side guard and provide the outer protective shell while mobile.

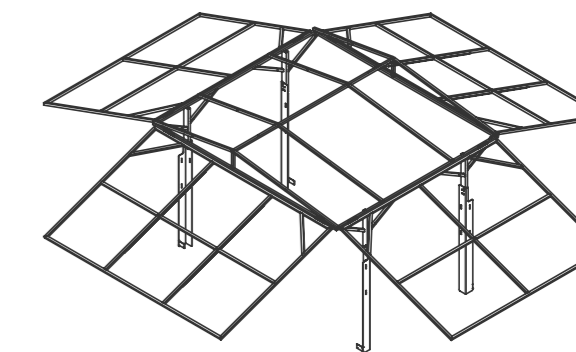
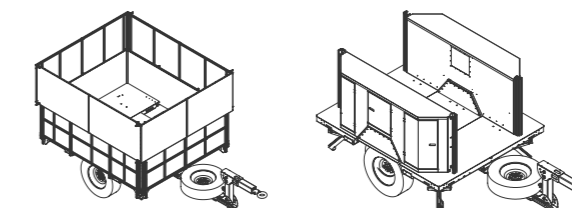

## Roof and Awnings

The roof is an aluminium frame fitted with a fire retardant, anti-tear canvas cover with exhaust and ventilation holes. Gas struts allow assembly in minutes. The roof can be fitted with an optional solar panel. The roof has a span of 18m<sup>2</sup>.

A further option is to fit awnings in order to fully enclose the unit for insulation against the elements.





# Assembly

## Watch Online

Go to the link below or scan the QR code with your phone to see a video demonstration of the ELW Diesel Field Kitchen being assembled.

<http://dieselfieldkitchen.com>



GET YOUR QR SCANNER  
<https://scan.me/download>

# Technical Specification

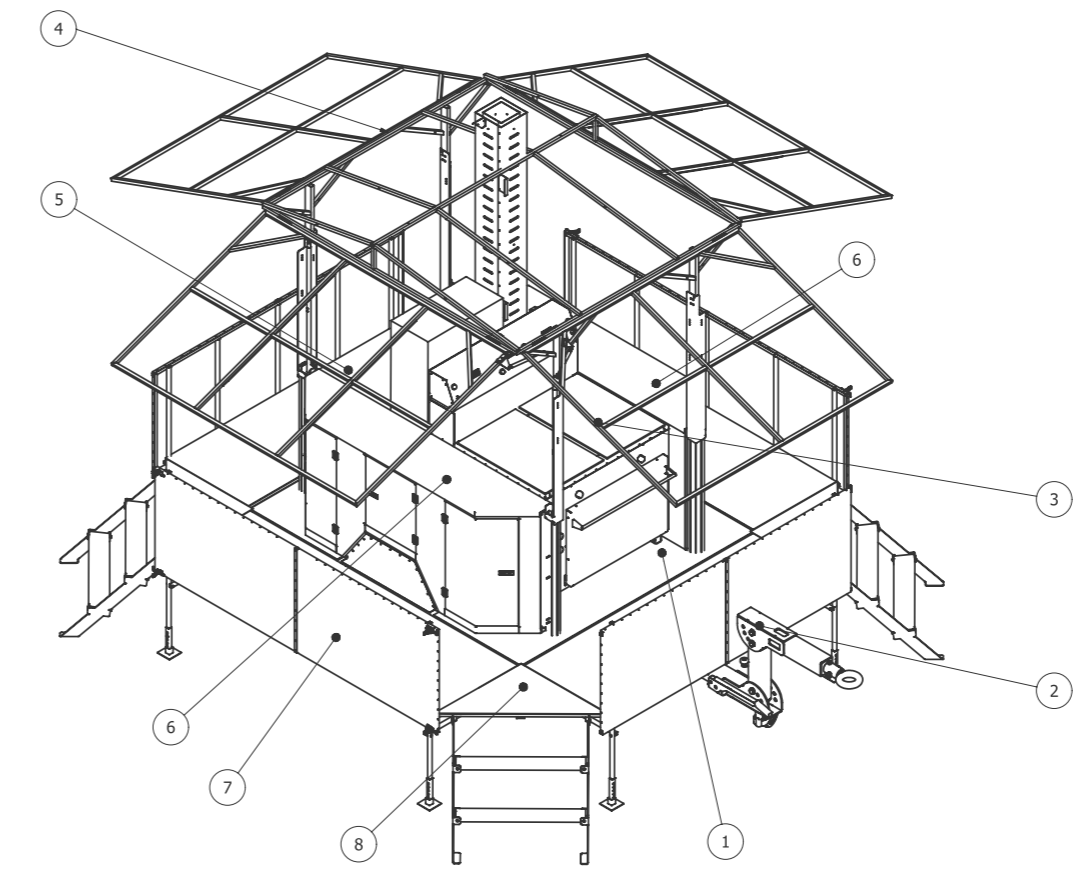

- 1. CHASSIS ASSEMBLY
- 2. DRAWBAR ASSEMBLY
- 3. STOVE ASSEMBLY
- 4. ROOF ASSEMBLY
- 5. SINK ASSEMBLY
- 6. CUPBOARD
- 7. SIDE PANEL & PLATFORM ASSEMBLY
- 8. PLATFORM TRIPLATE & STEPS





The ELW Diesel Field Kitchen is suited to all environments and terrains and can be supplied in various colour options depending on use.



### Colour Options

The standard colours are Tan / Military Green / Woodland Camo / UN White. Any additional colours are available by request, contact us for further details.







ELW Global Limited  
12 Quark Crescent, Linbro Business Park  
Sandton, 2090, Johannesburg  
South Africa

Office : + 27 11 608 2515  
Email : info@elwglobal.com

www.elwtactical.com  
www.dieselfieldkitchen.com



# ELW DFK

Diesel Field Kitchen

